

SUPPLIED FIXING KIT – DM64

DESC	QTY
M8X20mm BOLT	12
M8 NYLOC NUT	8
M8 WASHER	20
M8 SPRING WASHER	4

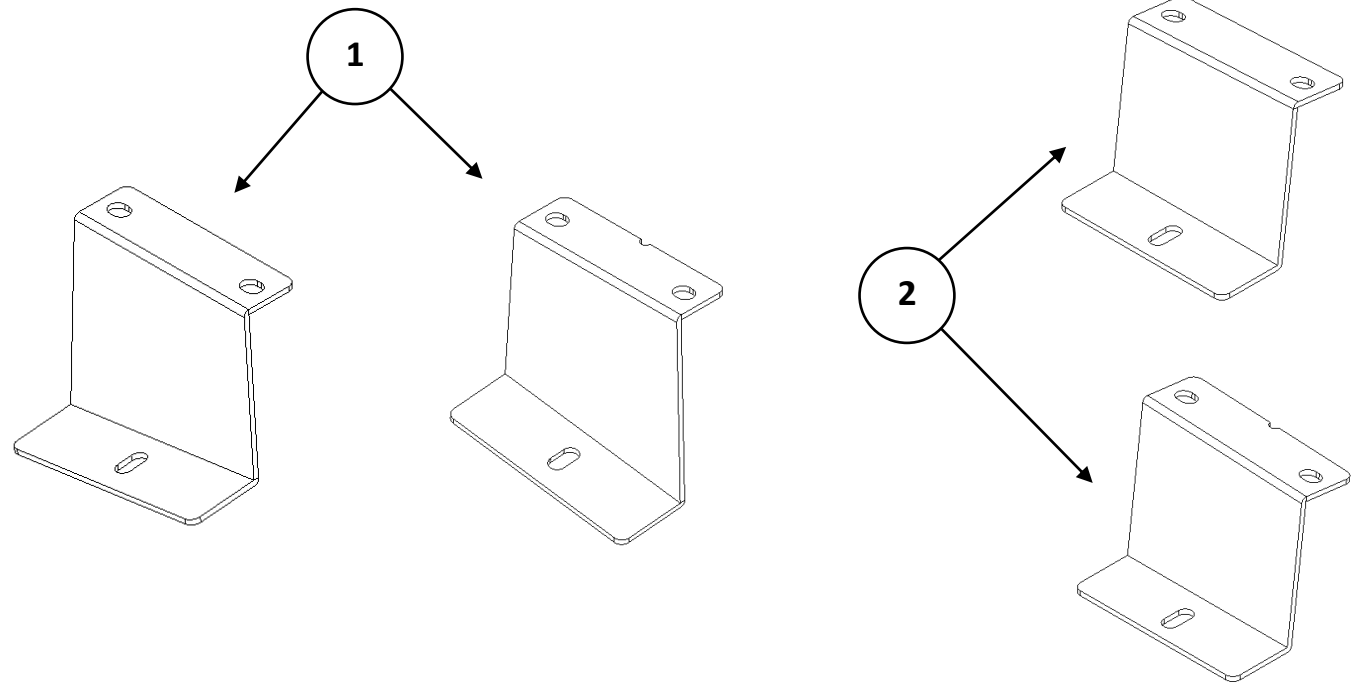

SUPPLIED COMPONENTS

#	DESC	QTY
1	RRP86	1 L, 1 R
2	RRP87	1 L, 1 R
3	RRP129	4
4	D BAR	2
5	SP6 RUBBER PAD	8

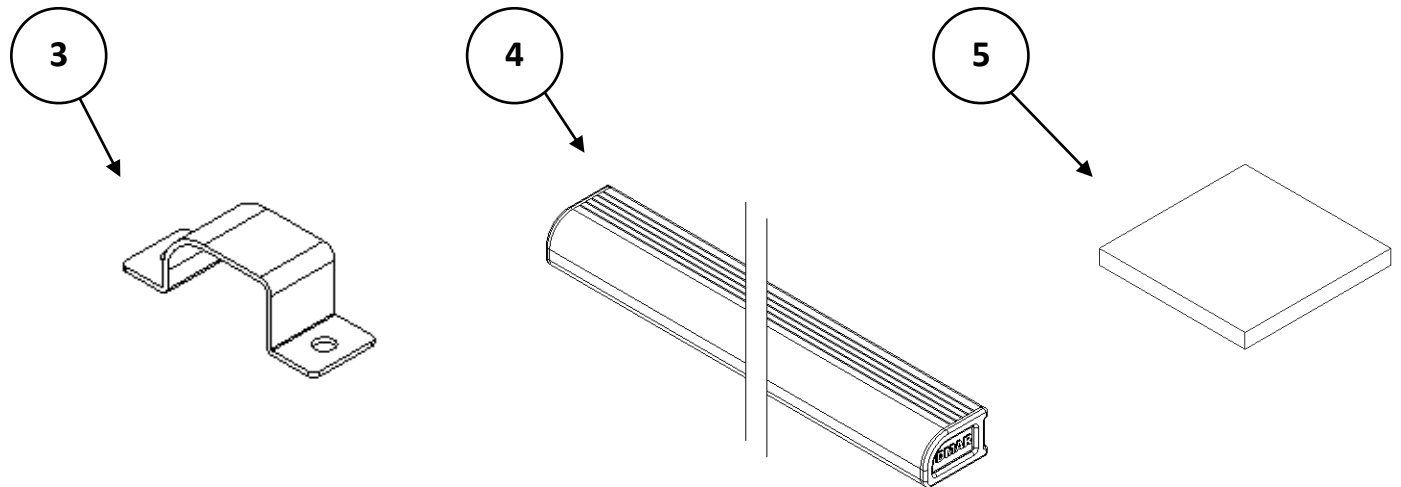

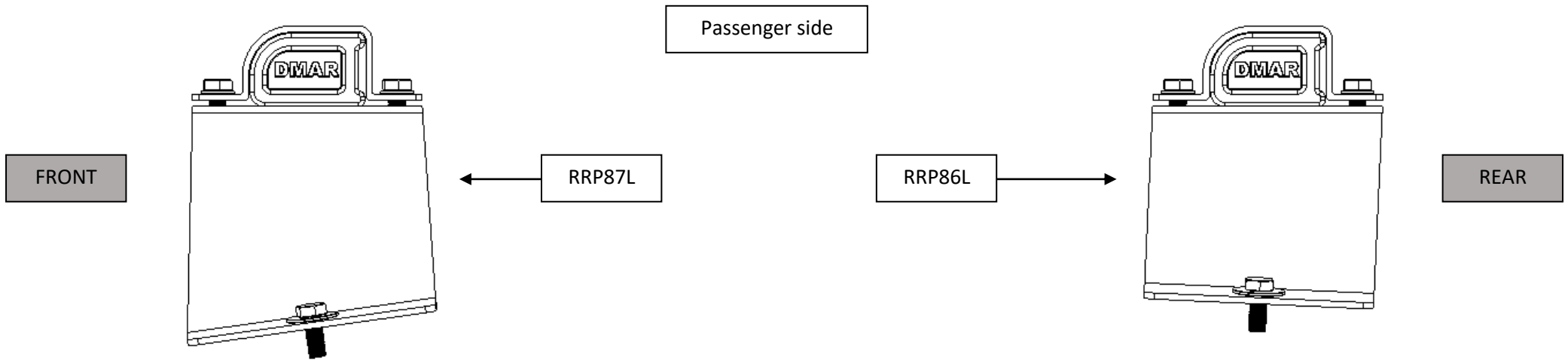

Bolt the RRP129 to the top of the RRP brackets.

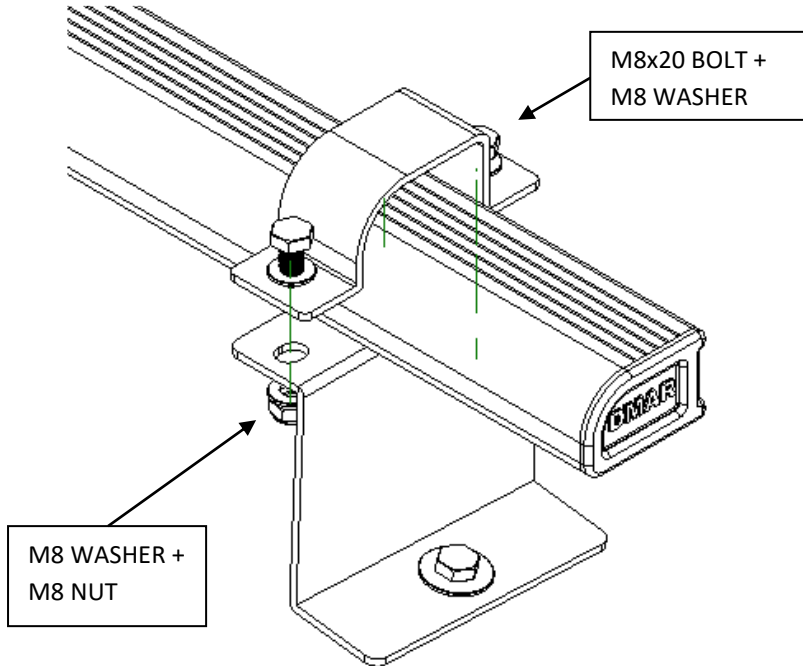

Leave all nuts finger tight at the moment.

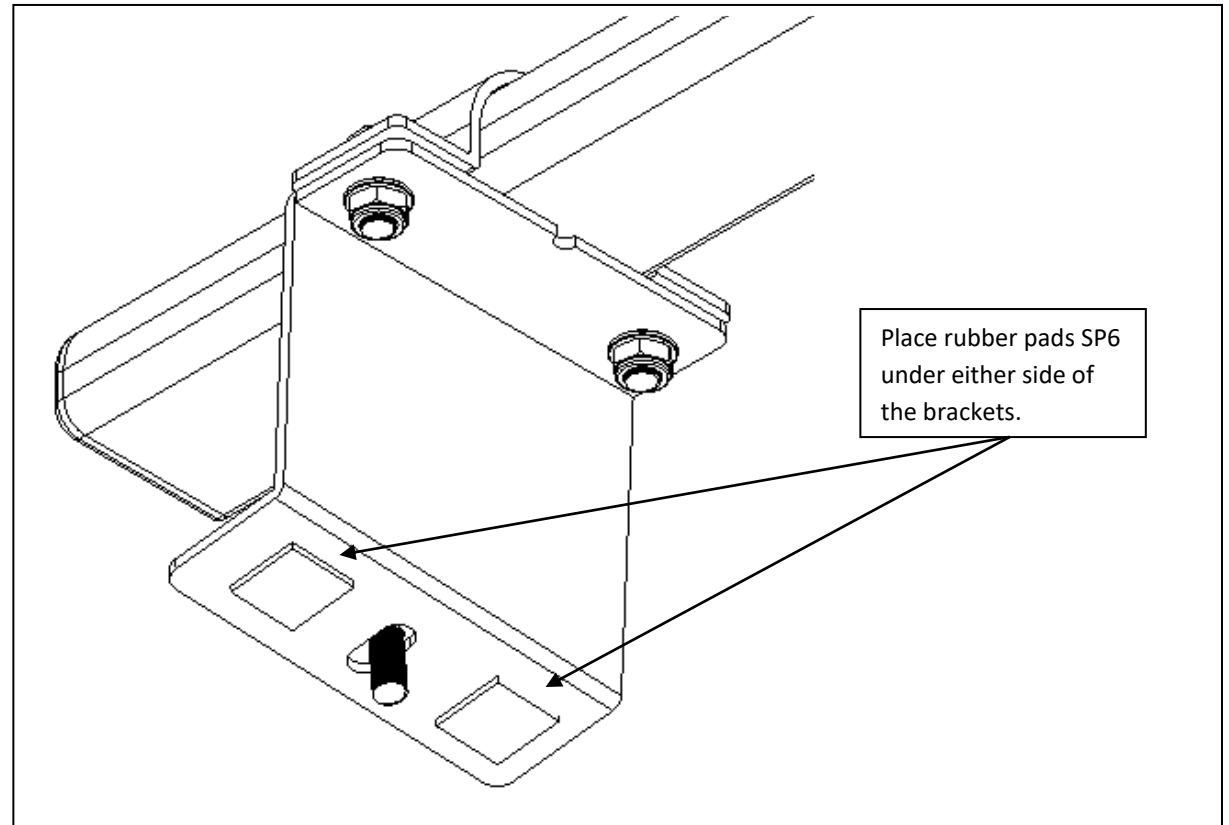

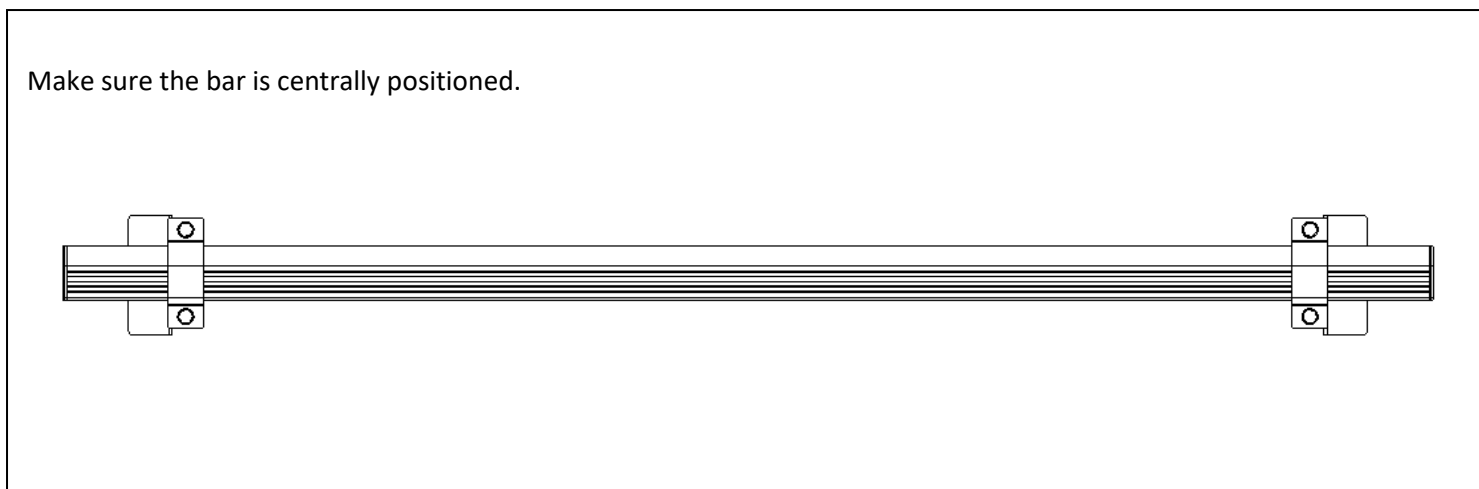
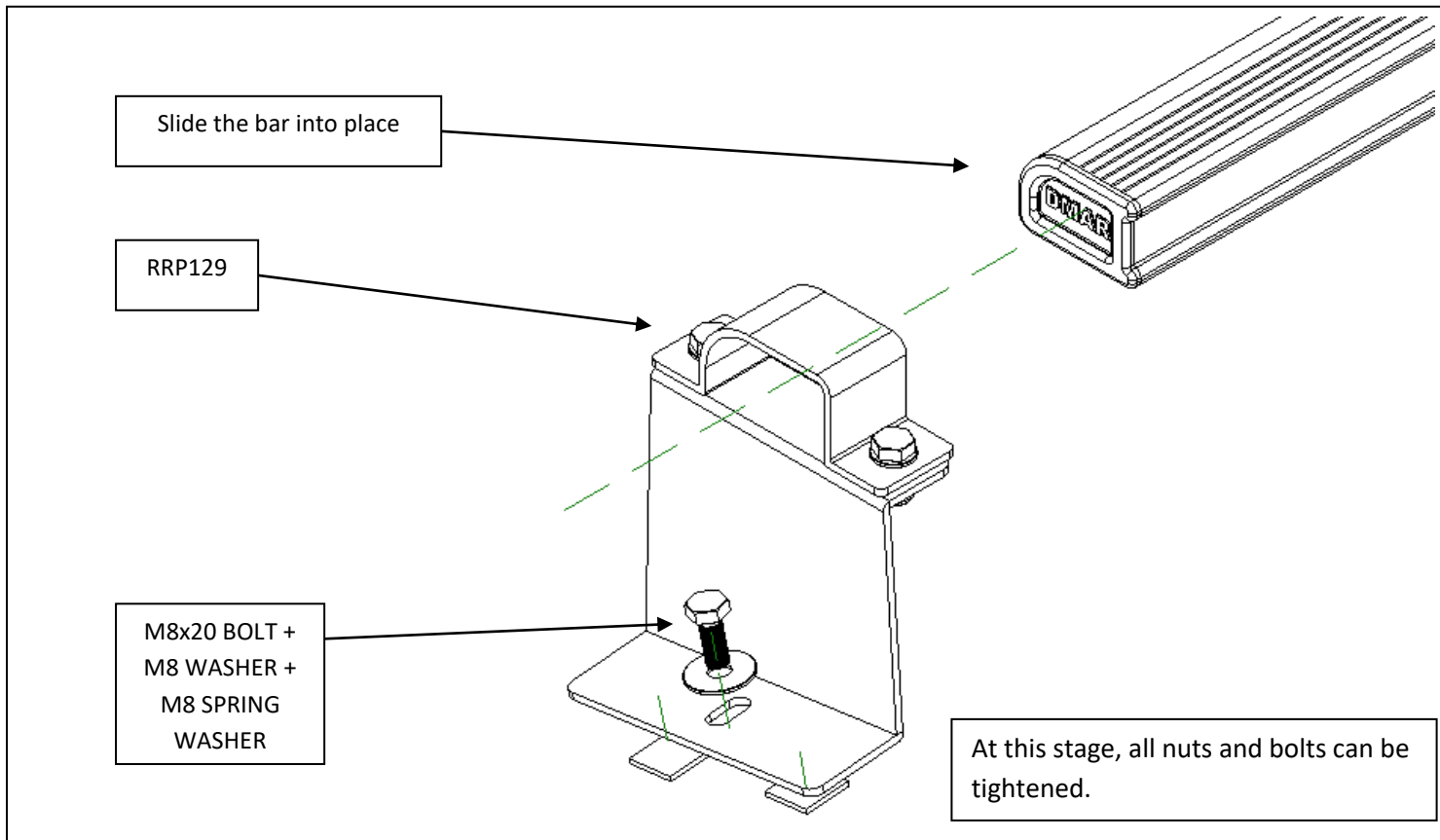

Once in position, tighten all fixings to **8Nm**.
Periodically check all fixings.



NOTES: Do not exceed vehicle manufacturers roof loading recommendations. Loads must be evenly distributed. All fixings and clamps need to be checked regularly for fatigue or wear and tightened or replaced when required. Paint damage to be touched up to prevent corrosion occurring. No liability is accepted by DEMAR for damage to vehicle or claims arising from use of roof rack. User must ensure all Health and Safety recommendations are complied.

